



## Introduction

Speedlock benches are made from the same beams and uprights that we use for our pallet racking, so they are the strongest benches around.

They can be easily assembled, and can be customised with the addition of a top shelf, or by adding maxi bins or high density drawer systems for small parts storage.

## Features

- A range of top options available
- Can be tailored to suit your available space
- Incorporate shelves for maximum organisation
- Tested in accordance with FEM 10.2.02
- Lifetime Warranty - conditions apply

# Speedlock work bench



## Configurations

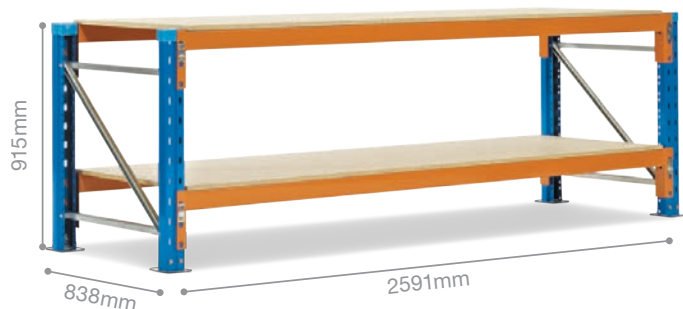

### Speedlock work bench.

75 Open beams with particle board work surface and bottom shelf.

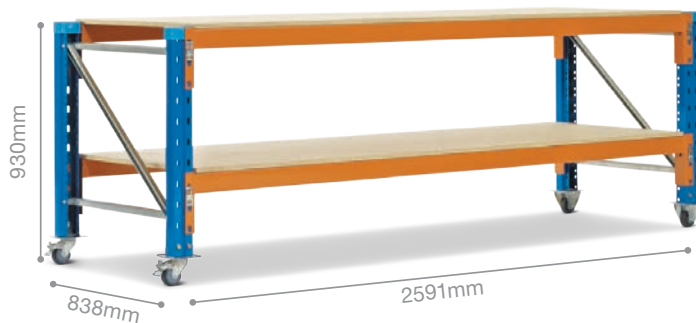

### Speedlock mobile work bench.

75 Open beams with particle board work surface and bottom shelf & castors.

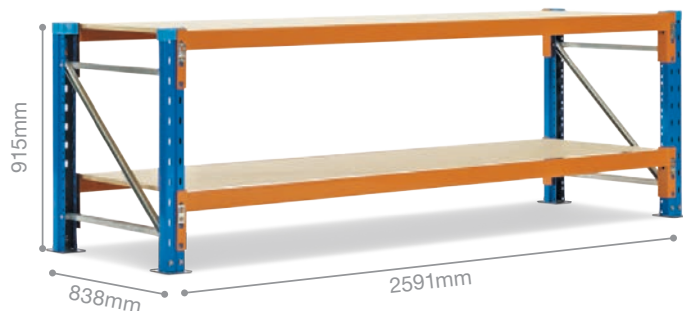

### Speedlock work bench.

80 Step beams with particle board work surface and bottom shelf.

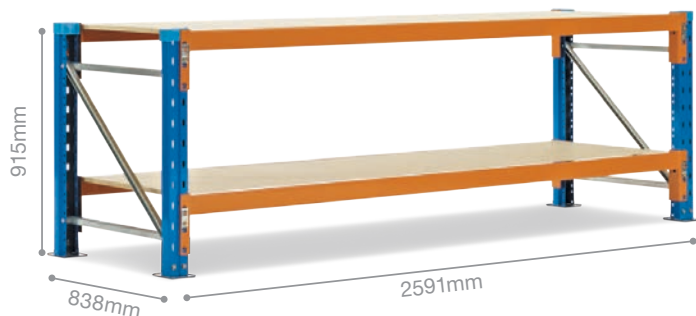

### Speedlock work bench.

75 Open beams with drop in particle board work surface and bottom shelf.



### Speedlock work bench.

75 Open beams with particle board work surface and upper and bottom shelf.

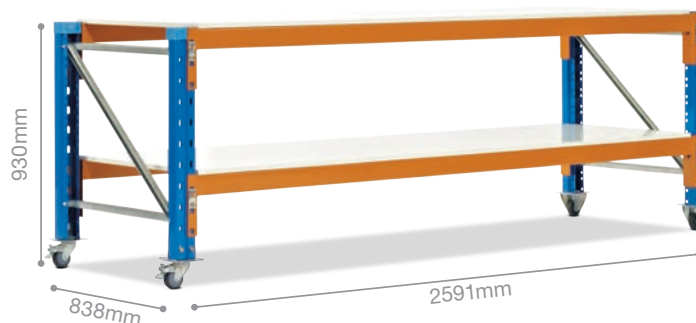

### Speedlock mobile work bench.

75 Open beams with melamine work surface and bottom shelf and castors.

Dexion® Compactus® Ultima® Freetrack® Speedlock® Keylock® Selecta-Flo® Marlbro® Spandex® Plan-D® Elite Built® First Line® Godfrey® Rola File® Vertiplan® Godfrey® Precision® Smartstore® Kurve® Mysite® and Adapt® are all registered trademarks.